

# CBT3251

## 1-of-8 FET multiplexer/demultiplexer

Rev. 01 — 21 December 2005

Product data sheet

## 1. General description

The CBT3251 is a 1-of-8 high-speed TTL-compatible FET multiplexer/demultiplexer. The low ON-resistance of the switch allows inputs to be connected to outputs without adding propagation delay or generating additional ground bounce noise.

When output enable ( $\overline{OE}$ ) is LOW, the CBT3251 is enabled. S0, S1, and S2 select one of the B outputs for the A-input data.

The CBT3251 is characterized for operation from  $-40\text{ }^{\circ}\text{C}$  to  $+85\text{ }^{\circ}\text{C}$ .

## 2. Features

- $5\ \Omega$  switch connection between two ports
- TTL-compatible input levels
- Minimal propagation delay through the switch
- ESD protection exceeds 2000 V HBM per JESD22-A114, 200 V MM per JESD22-A115 and 1000 V CDM per JESD22-C101
- Latch-up testing is done to JEDEC Standard JESD78 which exceeds 100 mA

## 3. Ordering information

Table 1: Ordering information

$T_{amb} = -40\text{ }^{\circ}\text{C}$  to  $+85\text{ }^{\circ}\text{C}$ .

Type number	Topside mark	Package		
		Name	Description	Version
CBT3251D	CBT3251D	SO16	plastic small outline package; 16 leads; body width 3.9 mm	SOT109-1
CBT3251DB	CT3251	SSOP16	plastic shrink small outline package; 16 leads; body width 5.3 mm	SOT338-1
CBT3251DS	CBT3251	SSOP16 [1]	plastic shrink small outline package; 16 leads; body width 3.9 mm; lead pitch 0.635 mm	SOT519-1
CBT3251PW	CBT3251	TSSOP16	plastic thin shrink small outline package; 16 leads; body width 4.4 mm	SOT403-1

[1] Also known as QSOP16.

**4. Functional diagram**

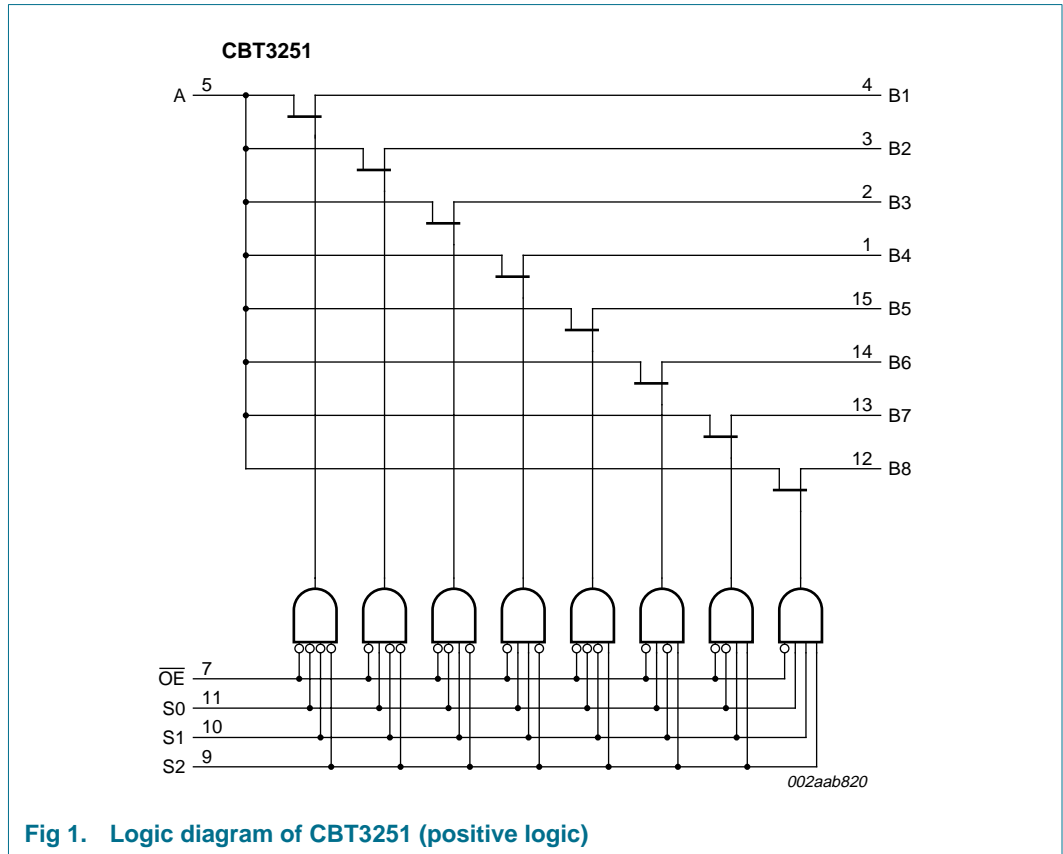

**Fig 1. Logic diagram of CBT3251 (positive logic)**

## 5. Pinning information

### 5.1 Pinning

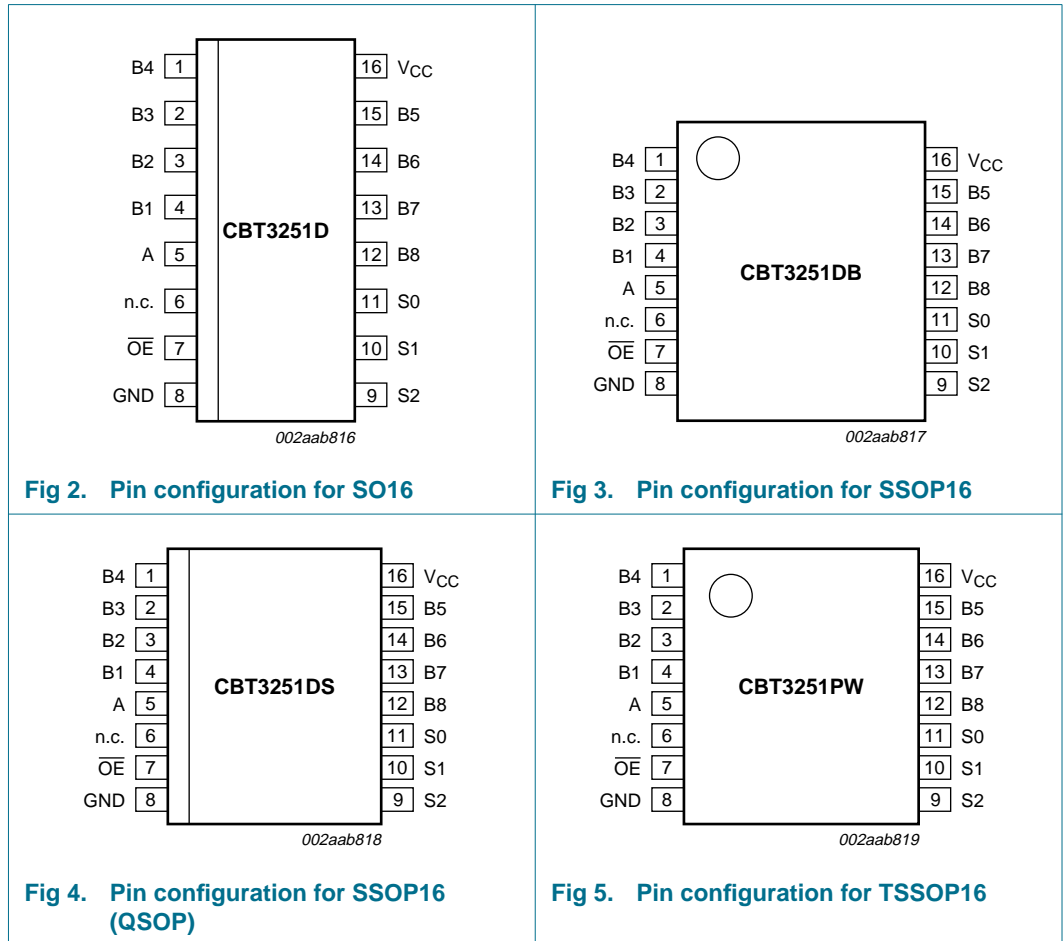

### 5.2 Pin description

**Table 2: Pin description**

Symbol	Pin	Description
B1, B2, B3, B4, B5, B6, B7, B8	1, 2, 3, 4, 12, 13, 14, 15	B outputs [1]
A	5	A input
n.c.	6	not connected
$\overline{OE}$	7	output enable (active LOW)
GND	8	ground (0 V)
$V_{CC}$	16	positive supply voltage

[1] B outputs are inputs if A inputs are outputs.

## 6. Functional description

Refer to [Figure 1 “Logic diagram of CBT3251 \(positive logic\)”](#).

### 6.1 Function selection

**Table 3: Function selection**

*H = HIGH state; L = LOW state; X = Don't Care.*

Inputs				Function
OE	S2	S1	S0	
L	L	L	L	A port = B1 port
L	L	L	H	A port = B2 port
L	L	H	L	A port = B3 port
L	L	H	H	A port = B4 port
L	H	L	L	A port = B5 port
L	H	L	H	A port = B6 port
L	H	H	L	A port = B7 port
L	H	H	H	A port = B8 port
H	X	X	X	disconnect

## 7. Limiting values

**Table 4: Limiting values**

*In accordance with the Absolute Maximum Rating System (IEC 60134).*

Symbol	Parameter	Conditions	Min	Max	Unit
$V_{CC}$	supply voltage		-0.5 [1]	+7.0	V
$V_I$	input voltage		-0.5 [1]	+7.0	V
$I_{CCC}$	continuous current through each $V_{CC}$ or GND pin		-	128	mA
$I_{IK}$	input clamping current	$V_I < 0$ V	-	-50	mA
$T_{stg}$	storage temperature		-65	+150	°C

[1] The input and output negative voltage ratings may be exceeded if the input and output clamp current ratings are observed.

## 8. Recommended operating conditions

**Table 5: Operating conditions**

Symbol	Parameter	Conditions	Min	Typ	Max	Unit
$V_{CC}$	supply voltage		4.5	-	5.5	V
$V_{IH}$	HIGH-state input voltage		2.0	-	-	V
$V_{IL}$	LOW-state input voltage		-	-	0.8	V
$T_{amb}$	ambient temperature	operating in free air	-40	-	+85	°C

[1] All unused control inputs of the device must be held at  $V_{CC}$  or GND to ensure proper device operation.

## 9. Static characteristics

**Table 6: Static characteristics**

$T_{amb} = -40\text{ }^{\circ}\text{C}$  to  $+85\text{ }^{\circ}\text{C}$ .

Symbol	Parameter	Conditions	Min	Typ [1]	Max	Unit
$V_{IK}$	input clamping voltage	$V_{CC} = 4.5\text{ V}$ ; $I_I = -18\text{ mA}$	-	-	-1.2	V
$V_{pass}$	pass voltage	$V_I = V_{CC} = 5.5\text{ V}$ ; $I_O = -100\text{ mA}$	3.4	3.6	3.9	V
$I_{LI}$	input leakage current	$V_{CC} = 5.5\text{ V}$ ; $V_I = \text{GND}$ or $5.5\text{ V}$	-	-	$\pm 1$	$\mu\text{A}$
$I_{CC}$	quiescent supply current	$V_{CC} = 5.5\text{ V}$ ; $I_O = 0\text{ mA}$ ; $V_I = \text{GND}$ or $5.5\text{ V}$	-	-	3	$\mu\text{A}$
$\Delta I_{CC}$	additional quiescent supply current	control inputs; $V_{CC} = 5.5\text{ V}$ ; one input at $3.4\text{ V}$ ; other inputs at $V_{CC}$ or $\text{GND}$	[2] -	-	2.5	$\text{mA}$
$C_i$	input capacitance	control pins; $V_I = 3\text{ V}$ or $0\text{ V}$	-	3.5	-	$\text{pF}$
$C_{io(off)}$	off-state input/output capacitance	A port; $V_I = 3\text{ V}$ or $0\text{ V}$ ; $\overline{OE} = V_{CC}$	-	17.5	-	$\text{pF}$
		B port; $V_I = 3\text{ V}$ or $0\text{ V}$ ; $\overline{OE} = V_{CC}$	-	4.0	-	$\text{pF}$
$R_{on}$	ON-state resistance	$V_{CC} = 4\text{ V}$ ; typ. at $V_{CC} = 4\text{ V}$ ; $V_I = 2.4\text{ V}$ ; $I_I = 15\text{ mA}$	[3] -	14	20	$\Omega$
		$V_{CC} = 4.5\text{ V}$ ; $V_I = 0\text{ V}$ ; $I_I = 64\text{ mA}$	[3] -	5	7	$\Omega$
		$V_{CC} = 4.5\text{ V}$ ; $V_I = 0\text{ V}$ ; $I_I = 30\text{ mA}$	[3] -	5	7	$\Omega$
		$V_{CC} = 4.5\text{ V}$ ; $V_I = 2.4\text{ V}$ ; $I_I = 15\text{ mA}$	[3] -	10	15	$\Omega$

[1] All typical values are at  $V_{CC} = 5\text{ V}$ ,  $T_{amb} = 25\text{ }^{\circ}\text{C}$ .

[2] This is the increase in supply current for each input that is at the specified TTL voltage level rather than  $V_{CC}$  or  $\text{GND}$ .

[3] Measured by the voltage drop between the A and the B terminals at the indicated current through the switch. ON-state resistance is determined by the lowest voltage of the two (A or B) terminals.

## 10. Dynamic characteristics

**Table 7: Dynamic characteristics**

$V_{CC} = +5.0\text{ V} \pm 0.5\text{ V}$ ;  $T_{amb} = -40\text{ }^{\circ}\text{C}$  to  $+85\text{ }^{\circ}\text{C}$ ; unless otherwise specified.

Symbol	Parameter	Conditions	Min	Typ	Max	Unit
$t_{PD}$	propagation delay	from input (A or Bn) to output (Bn or A)	[1] -	-	0.25	ns
		from input (Sn) to output (A)	2	-	5.5	ns
$t_{en}$	enable time [2]	from input (Sn) to output (Bn)	1.5	-	5.6	ns
		from input ( $\overline{OE}$ ) to output (A or Bn)	1.6	-	5.8	ns
$t_{dis}$	disable time [3]	from input (Sn) to output (Bn)	1.9	-	6.4	ns
		from input ( $\overline{OE}$ ) to output (A or Bn)	2.3	-	6.2	ns

[1] The propagation delay is the calculated RC time constant of the typical ON-state resistance of the switch and the specified load capacitance, when driven by an ideal voltage source (zero output impedance).

[2] Output enable time to HIGH and LOW level.

[3] Output disable time from HIGH and LOW level.

10.1 AC waveforms

$V_I = \text{GND to } 3.0 \text{ V.}$

$t_{PLZ}$  and  $t_{PHZ}$  are the same as  $t_{dis}$ .

$t_{PZL}$  and  $t_{PZH}$  are the same as  $t_{en}$ .

$t_{PLH}$  and  $t_{PHL}$  are the same as  $t_{PD}$ .

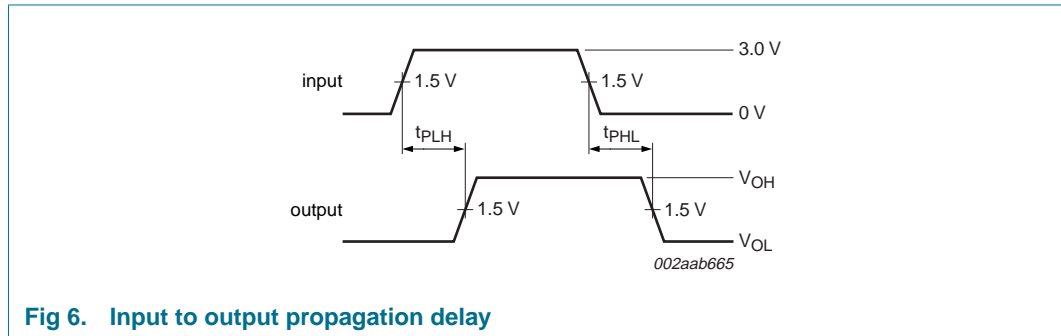
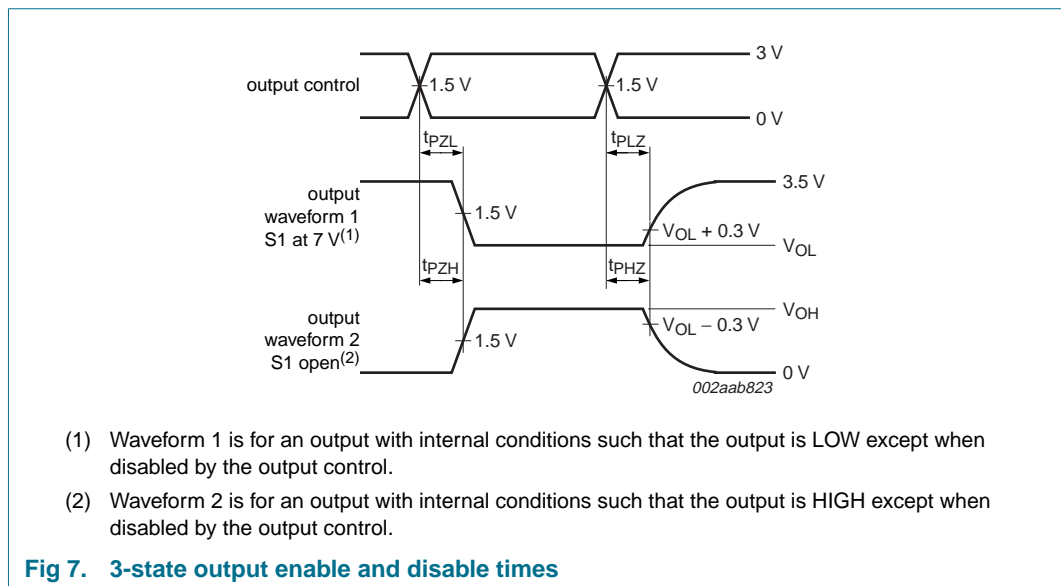

Fig 6. Input to output propagation delay



- (1) Waveform 1 is for an output with internal conditions such that the output is LOW except when disabled by the output control.
- (2) Waveform 2 is for an output with internal conditions such that the output is HIGH except when disabled by the output control.

Fig 7. 3-state output enable and disable times

## 11. Test information

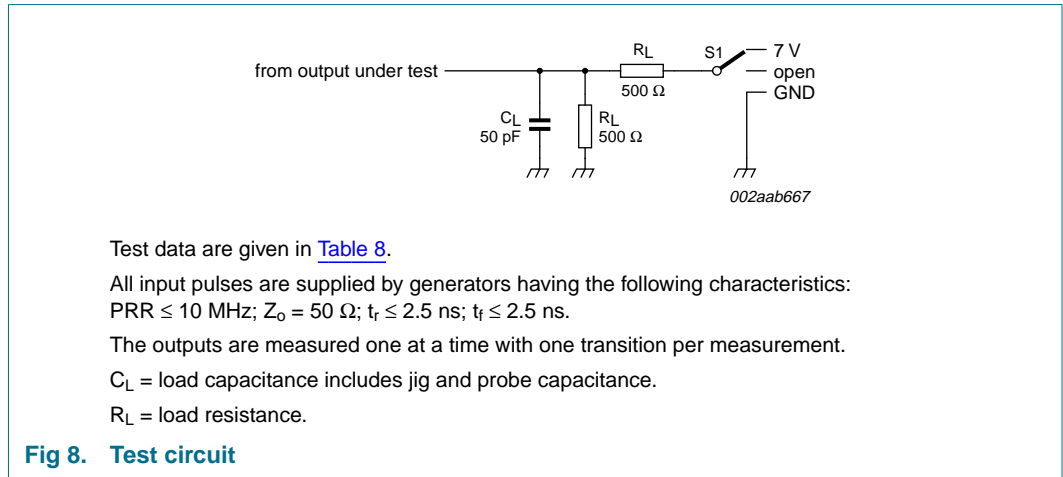

**Table 8: Test data**

Test	Load		Switch
	$C_L$	$R_L$	
$t_{PD}$	50 pF	500 $\Omega$	open
$t_{PLZ}$ , $t_{PZL}$	50 pF	500 $\Omega$	7 V
$t_{PHZ}$ , $t_{PZH}$	50 pF	500 $\Omega$	open

12. Package outline

SO16: plastic small outline package; 16 leads; body width 3.9 mm

SOT109-1

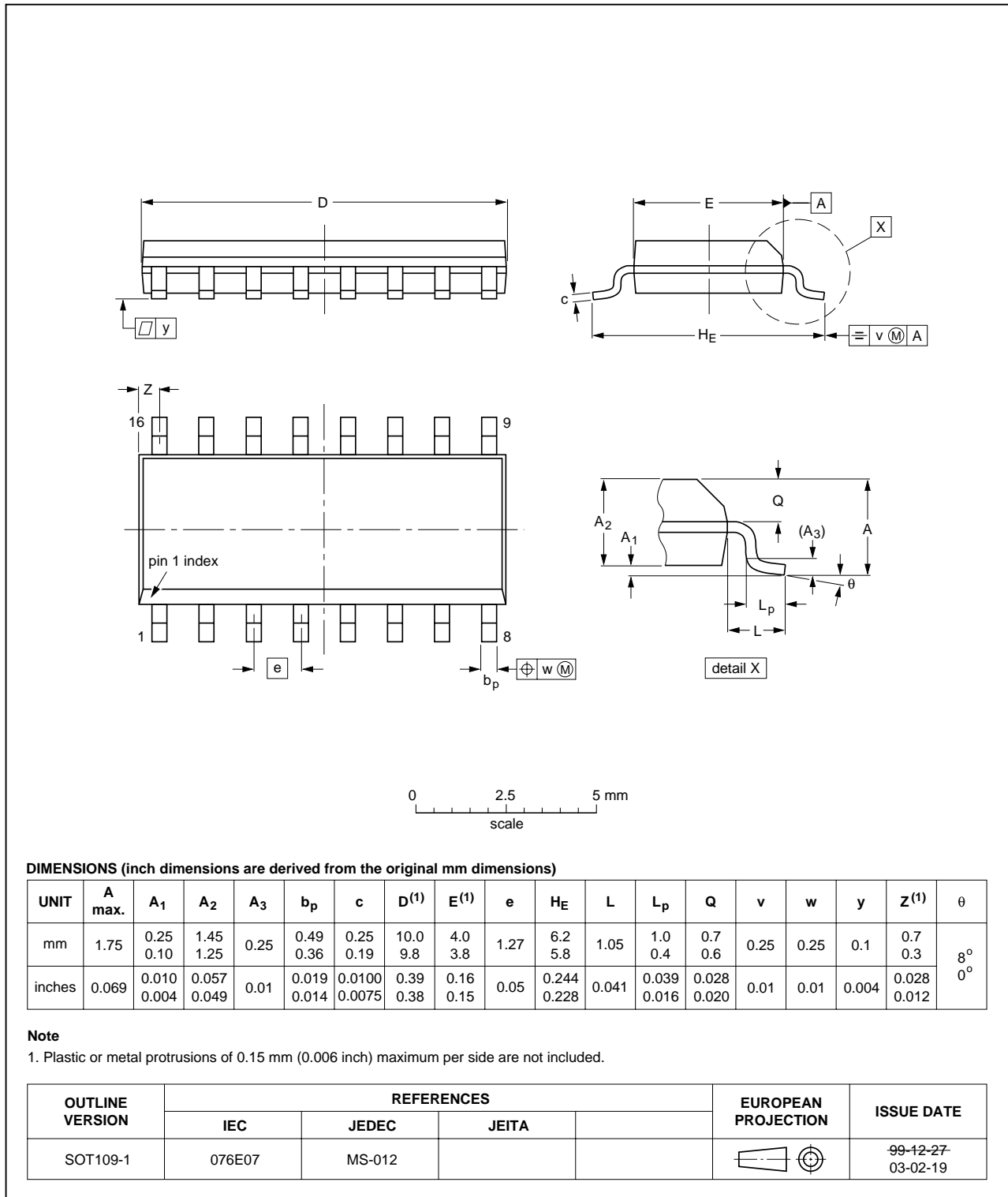

Fig 9. Package outline SOT109-1 (SO16)



SSOP16: plastic shrink small outline package; 16 leads; body width 5.3 mm

SOT338-1

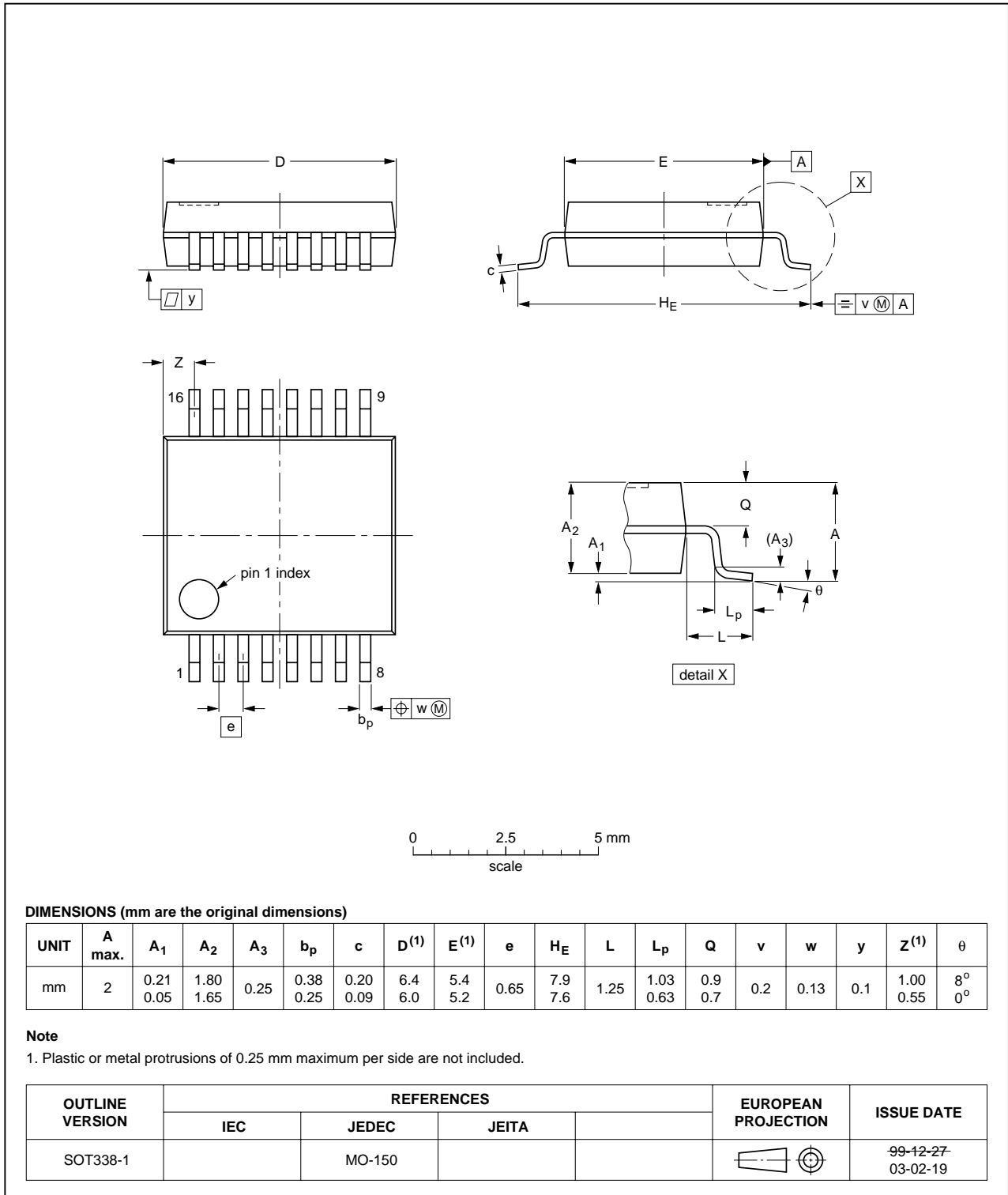

Fig 10. Package outline SOT338-1 (SSOP16)

SSOP16: plastic shrink small outline package; 16 leads; body width 3.9 mm; lead pitch 0.635 mm SOT519-1

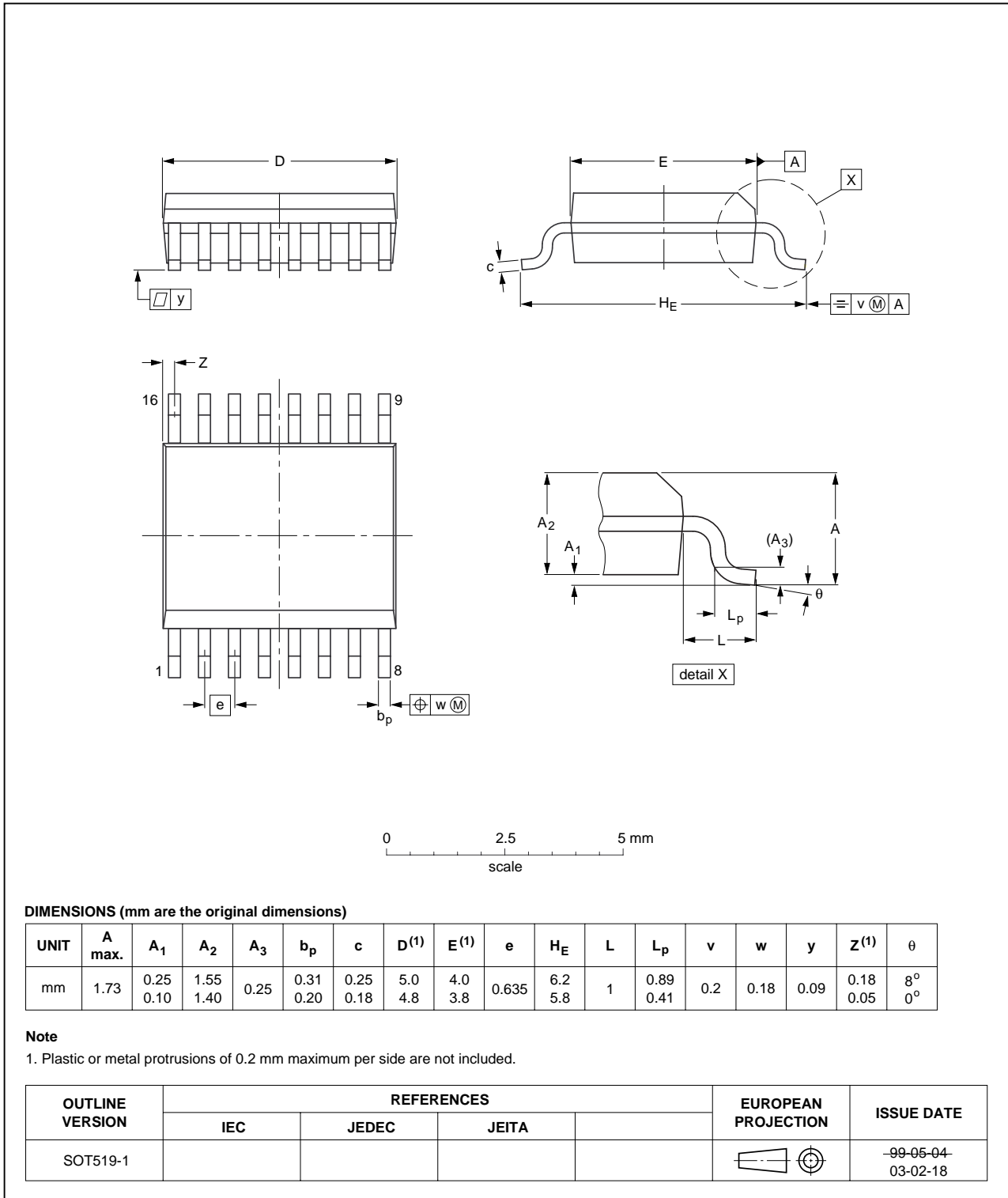

Fig 11. Package outline SOT519-1 (SSOP16)

TSSOP16: plastic thin shrink small outline package; 16 leads; body width 4.4 mm

SOT403-1

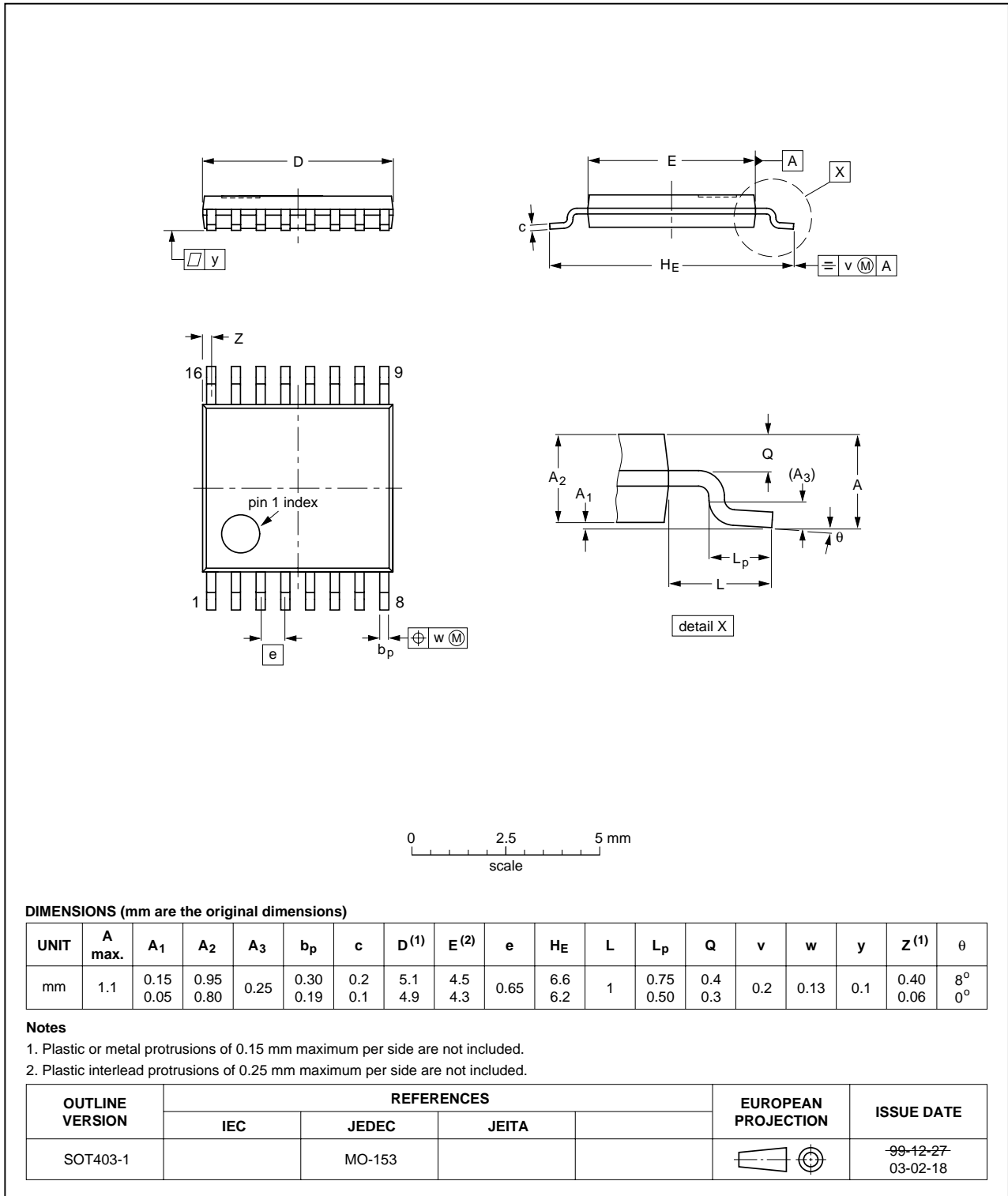

Fig 12. Package outline SOT403-1 (TSSOP16)

## 13. Soldering

### 13.1 Introduction to soldering surface mount packages

This text gives a very brief insight to a complex technology. A more in-depth account of soldering ICs can be found in our *Data Handbook IC26; Integrated Circuit Packages* (document order number 9398 652 90011).

There is no soldering method that is ideal for all surface mount IC packages. Wave soldering can still be used for certain surface mount ICs, but it is not suitable for fine pitch SMDs. In these situations reflow soldering is recommended.

### 13.2 Reflow soldering

Reflow soldering requires solder paste (a suspension of fine solder particles, flux and binding agent) to be applied to the printed-circuit board by screen printing, stencilling or pressure-syringe dispensing before package placement. Driven by legislation and environmental forces the worldwide use of lead-free solder pastes is increasing.

Several methods exist for reflowing; for example, convection or convection/infrared heating in a conveyor type oven. Throughput times (preheating, soldering and cooling) vary between 100 seconds and 200 seconds depending on heating method.

Typical reflow peak temperatures range from 215 °C to 270 °C depending on solder paste material. The top-surface temperature of the packages should preferably be kept:

- below 225 °C (SnPb process) or below 245 °C (Pb-free process)
  - for all BGA, HTSSON..T and SSOP..T packages
  - for packages with a thickness  $\geq 2.5$  mm
  - for packages with a thickness  $< 2.5$  mm and a volume  $\geq 350$  mm<sup>3</sup> so called thick/large packages.
- below 240 °C (SnPb process) or below 260 °C (Pb-free process) for packages with a thickness  $< 2.5$  mm and a volume  $< 350$  mm<sup>3</sup> so called small/thin packages.

Moisture sensitivity precautions, as indicated on packing, must be respected at all times.

### 13.3 Wave soldering

Conventional single wave soldering is not recommended for surface mount devices (SMDs) or printed-circuit boards with a high component density, as solder bridging and non-wetting can present major problems.

To overcome these problems the double-wave soldering method was specifically developed.

If wave soldering is used the following conditions must be observed for optimal results:

- Use a double-wave soldering method comprising a turbulent wave with high upward pressure followed by a smooth laminar wave.
- For packages with leads on two sides and a pitch (e):
  - larger than or equal to 1.27 mm, the footprint longitudinal axis is **preferred** to be parallel to the transport direction of the printed-circuit board;

- smaller than 1.27 mm, the footprint longitudinal axis **must** be parallel to the transport direction of the printed-circuit board.

The footprint must incorporate solder thieves at the downstream end.

- For packages with leads on four sides, the footprint must be placed at a 45° angle to the transport direction of the printed-circuit board. The footprint must incorporate solder thieves downstream and at the side corners.

During placement and before soldering, the package must be fixed with a droplet of adhesive. The adhesive can be applied by screen printing, pin transfer or syringe dispensing. The package can be soldered after the adhesive is cured.

Typical dwell time of the leads in the wave ranges from 3 seconds to 4 seconds at 250 °C or 265 °C, depending on solder material applied, SnPb or Pb-free respectively.

A mildly-activated flux will eliminate the need for removal of corrosive residues in most applications.

### 13.4 Manual soldering

Fix the component by first soldering two diagonally-opposite end leads. Use a low voltage (24 V or less) soldering iron applied to the flat part of the lead. Contact time must be limited to 10 seconds at up to 300 °C.

When using a dedicated tool, all other leads can be soldered in one operation within 2 seconds to 5 seconds between 270 °C and 320 °C.

### 13.5 Package related soldering information

**Table 9: Suitability of surface mount IC packages for wave and reflow soldering methods**

Package [1]	Soldering method	
	Wave	Reflow [2]
BGA, HTSSON..T [3], LBGA, LFBGA, SQFP, SSOP..T [3], TFBGA, VFBGA, XSON	not suitable	suitable
DHVQFN, HBCC, HBGA, HLQFP, HSO, HSOP, HSQFP, HSSON, HTQFP, HTSSOP, HVQFN, HVSON, SMS	not suitable [4]	suitable
PLCC [5], SO, SOJ	suitable	suitable
LQFP, QFP, TQFP	not recommended [5] [6]	suitable
SSOP, TSSOP, VSO, VSSOP	not recommended [7]	suitable
CWQCCN..L [8], PMFP [9], WQCCN..L [8]	not suitable	not suitable

[1] For more detailed information on the BGA packages refer to the *(LF)BGA Application Note (AN01026)*; order a copy from your Philips Semiconductors sales office.

[2] All surface mount (SMD) packages are moisture sensitive. Depending upon the moisture content, the maximum temperature (with respect to time) and body size of the package, there is a risk that internal or external package cracks may occur due to vaporization of the moisture in them (the so called popcorn effect). For details, refer to the Drypack information in the *Data Handbook IC26; Integrated Circuit Packages; Section: Packing Methods*.

[3] These transparent plastic packages are extremely sensitive to reflow soldering conditions and must on no account be processed through more than one soldering cycle or subjected to infrared reflow soldering with peak temperature exceeding 217 °C ± 10 °C measured in the atmosphere of the reflow oven. The package body peak temperature must be kept as low as possible.

- [4] These packages are not suitable for wave soldering. On versions with the heatsink on the bottom side, the solder cannot penetrate between the printed-circuit board and the heatsink. On versions with the heatsink on the top side, the solder might be deposited on the heatsink surface.
- [5] If wave soldering is considered, then the package must be placed at a 45° angle to the solder wave direction. The package footprint must incorporate solder thieves downstream and at the side corners.
- [6] Wave soldering is suitable for LQFP, QFP and TQFP packages with a pitch (e) larger than 0.8 mm; it is definitely not suitable for packages with a pitch (e) equal to or smaller than 0.65 mm.
- [7] Wave soldering is suitable for SSOP, TSSOP, VSO and VSSOP packages with a pitch (e) equal to or larger than 0.65 mm; it is definitely not suitable for packages with a pitch (e) equal to or smaller than 0.5 mm.
- [8] Image sensor packages in principle should not be soldered. They are mounted in sockets or delivered pre-mounted on flex foil. However, the image sensor package can be mounted by the client on a flex foil by using a hot bar soldering process. The appropriate soldering profile can be provided on request.
- [9] Hot bar soldering or manual soldering is suitable for PMFP packages.

## 14. Abbreviations

**Table 10: Abbreviations**

Acronym	Description
CDM	Charged Device Model
ESD	ElectroStatic Discharge
FET	Field-Effect Transistor
HBM	Human Body Model
MM	Machine Model
PRR	Pulse Repetition Rate
TTL	Transistor-Transistor Logic

## 15. Revision history

**Table 11: Revision history**

Document ID	Release date	Data sheet status	Change notice	Doc. number	Supersedes
CBT3251_1	20051221	Product data sheet	-	-	-

## 16. Data sheet status

Level	Data sheet status <sup>[1]</sup>	Product status <sup>[2] [3]</sup>	Definition
I	Objective data	Development	This data sheet contains data from the objective specification for product development. Philips Semiconductors reserves the right to change the specification in any manner without notice.
II	Preliminary data	Qualification	This data sheet contains data from the preliminary specification. Supplementary data will be published at a later date. Philips Semiconductors reserves the right to change the specification without notice, in order to improve the design and supply the best possible product.
III	Product data	Production	This data sheet contains data from the product specification. Philips Semiconductors reserves the right to make changes at any time in order to improve the design, manufacturing and supply. Relevant changes will be communicated via a Customer Product/Process Change Notification (CPCN).

[1] Please consult the most recently issued data sheet before initiating or completing a design.

[2] The product status of the device(s) described in this data sheet may have changed since this data sheet was published. The latest information is available on the Internet at URL <http://www.semiconductors.philips.com>.

[3] For data sheets describing multiple type numbers, the highest-level product status determines the data sheet status.

## 17. Definitions

**Short-form specification** — The data in a short-form specification is extracted from a full data sheet with the same type number and title. For detailed information see the relevant data sheet or data handbook.

**Limiting values definition** — Limiting values given are in accordance with the Absolute Maximum Rating System (IEC 60134). Stress above one or more of the limiting values may cause permanent damage to the device. These are stress ratings only and operation of the device at these or at any other conditions above those given in the Characteristics sections of the specification is not implied. Exposure to limiting values for extended periods may affect device reliability.

**Application information** — Applications that are described herein for any of these products are for illustrative purposes only. Philips Semiconductors makes no representation or warranty that such applications will be suitable for the specified use without further testing or modification.

## 18. Disclaimers

**Life support** — These products are not designed for use in life support appliances, devices, or systems where malfunction of these products can reasonably be expected to result in personal injury. Philips Semiconductors

## 20. Contact information

For additional information, please visit: <http://www.semiconductors.philips.com>

For sales office addresses, send an email to: [sales.addresses@www.semiconductors.philips.com](mailto:sales.addresses@www.semiconductors.philips.com)

customers using or selling these products for use in such applications do so at their own risk and agree to fully indemnify Philips Semiconductors for any damages resulting from such application.

**Right to make changes** — Philips Semiconductors reserves the right to make changes in the products - including circuits, standard cells, and/or software - described or contained herein in order to improve design and/or performance. When the product is in full production (status 'Production'), relevant changes will be communicated via a Customer Product/Process Change Notification (CPCN). Philips Semiconductors assumes no responsibility or liability for the use of any of these products, conveys no license or title under any patent, copyright, or mask work right to these products, and makes no representations or warranties that these products are free from patent, copyright, or mask work right infringement, unless otherwise specified.

## 19. Trademarks

**Notice** — All referenced brands, product names, service names and trademarks are the property of their respective owners.

## 21. Contents

<b>1</b>	<b>General description</b> .....	<b>1</b>
<b>2</b>	<b>Features</b> .....	<b>1</b>
<b>3</b>	<b>Ordering information</b> .....	<b>1</b>
<b>4</b>	<b>Functional diagram</b> .....	<b>2</b>
<b>5</b>	<b>Pinning information</b> .....	<b>3</b>
5.1	Pinning .....	3
5.2	Pin description .....	3
<b>6</b>	<b>Functional description</b> .....	<b>4</b>
6.1	Function selection .....	4
<b>7</b>	<b>Limiting values</b> .....	<b>4</b>
<b>8</b>	<b>Recommended operating conditions</b> .....	<b>4</b>
<b>9</b>	<b>Static characteristics</b> .....	<b>5</b>
<b>10</b>	<b>Dynamic characteristics</b> .....	<b>5</b>
10.1	AC waveforms .....	6
<b>11</b>	<b>Test information</b> .....	<b>7</b>
<b>12</b>	<b>Package outline</b> .....	<b>8</b>
<b>13</b>	<b>Soldering</b> .....	<b>12</b>
13.1	Introduction to soldering surface mount packages .....	12
13.2	Reflow soldering .....	12
13.3	Wave soldering .....	12
13.4	Manual soldering .....	13
13.5	Package related soldering information .....	13
<b>14</b>	<b>Abbreviations</b> .....	<b>14</b>
<b>15</b>	<b>Revision history</b> .....	<b>14</b>
<b>16</b>	<b>Data sheet status</b> .....	<b>15</b>
<b>17</b>	<b>Definitions</b> .....	<b>15</b>
<b>18</b>	<b>Disclaimers</b> .....	<b>15</b>
<b>19</b>	<b>Trademarks</b> .....	<b>15</b>
<b>20</b>	<b>Contact information</b> .....	<b>15</b>



© Koninklijke Philips Electronics N.V. 2005

All rights are reserved. Reproduction in whole or in part is prohibited without the prior written consent of the copyright owner. The information presented in this document does not form part of any quotation or contract, is believed to be accurate and reliable and may be changed without notice. No liability will be accepted by the publisher for any consequence of its use. Publication thereof does not convey nor imply any license under patent- or other industrial or intellectual property rights.

Date of release: 21 December 2005  
Document number: CBT3251\_1

Published in The Netherlands